

# FlyDragonF722 v2 FBL Specifications\_20231231

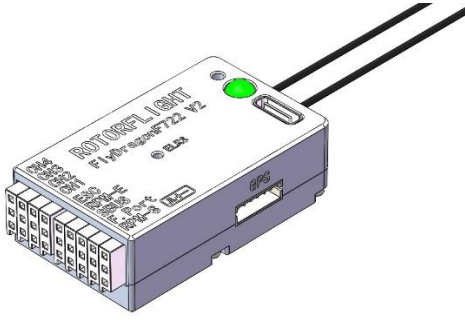

**About:** FlyDragon FBL is a flight controller for the Rotorflight open-source project. It features STM32F722 MCU, BMI270 IMU, Built-in ELRS receiver, and 128MB blackbox which enables the full potential of the Rotorflight flight experience in a small package. Rotorflight stems from on Betaflight 4.3 and borrows ideas from Heliflight3D. It shares all the great features Betaflight has to offer plus many new features developed specifically for helicopter platforms.

[Rotorflight open-source FBL]

Link: <https://github.com/rotorflight>

[Baidu pan]

Link: <https://pan.baidu.com/s/1pF4Tn6WrMd8owsCTOvsVUw>

Extraction code: owpb

[Ali pan]

Link: <https://www.aliyundrive.com/s/G516rDpKBU6>

Extraction code: 35yq

**Flight Mode:** Acro, Angle, Horizon, Rescue. etc.

## Hardware Specifications:

**MCU:** STM32F722RET6

**IMU:** BMI270

**Black Box:** W25N01G (128MB)

**Baro:** SPL06 (I<sup>2</sup>C2)

**LED:** WS2812

**Beeper:** 5V Active Buzzer

**USB:** Type-C

**UARTS:** UART2, UART3, UART5

**I<sup>2</sup>C:** I<sup>2</sup>C1

**ADC:** ADC1 (12S)

**Servo Pins:** CH1-CH4

**RPM Inputs:** RPM\_E (ESC RPM Wire), RPM\_S (External RPM Sensor)

**Internal Receiver:** ELRS Diversity Receiver 2.4G (UART1)

**External Receiver:** CRSF, S.BUS, F.PORT, GHOST, SUMD, SUMH, IBUS, XBUS, XBUS/RJ01, EXBUS, PPM, MSP, DSM (Needs 3.3V step-down BEC module)

**BEC Voltage:** 5-15V

**5V Power Output:** 5V-1.5A

**ESC Protocols:** PWM, ONESHOT125, ONESHOT42, MULTISHOT, BRUSHED, DSHOT150, DSHOT300, DSHOT600, PROSHOT

**ESC Telemetry:** BLHeli32, Hobbywing V4, Hobbywing V5, Scorpion, Kontronik, OMPHOBBY, ZTW, APD

**Dimensions:** 45mm x 27mm x 14.5mm

**Weight:** 27g

## Wiring Diagram

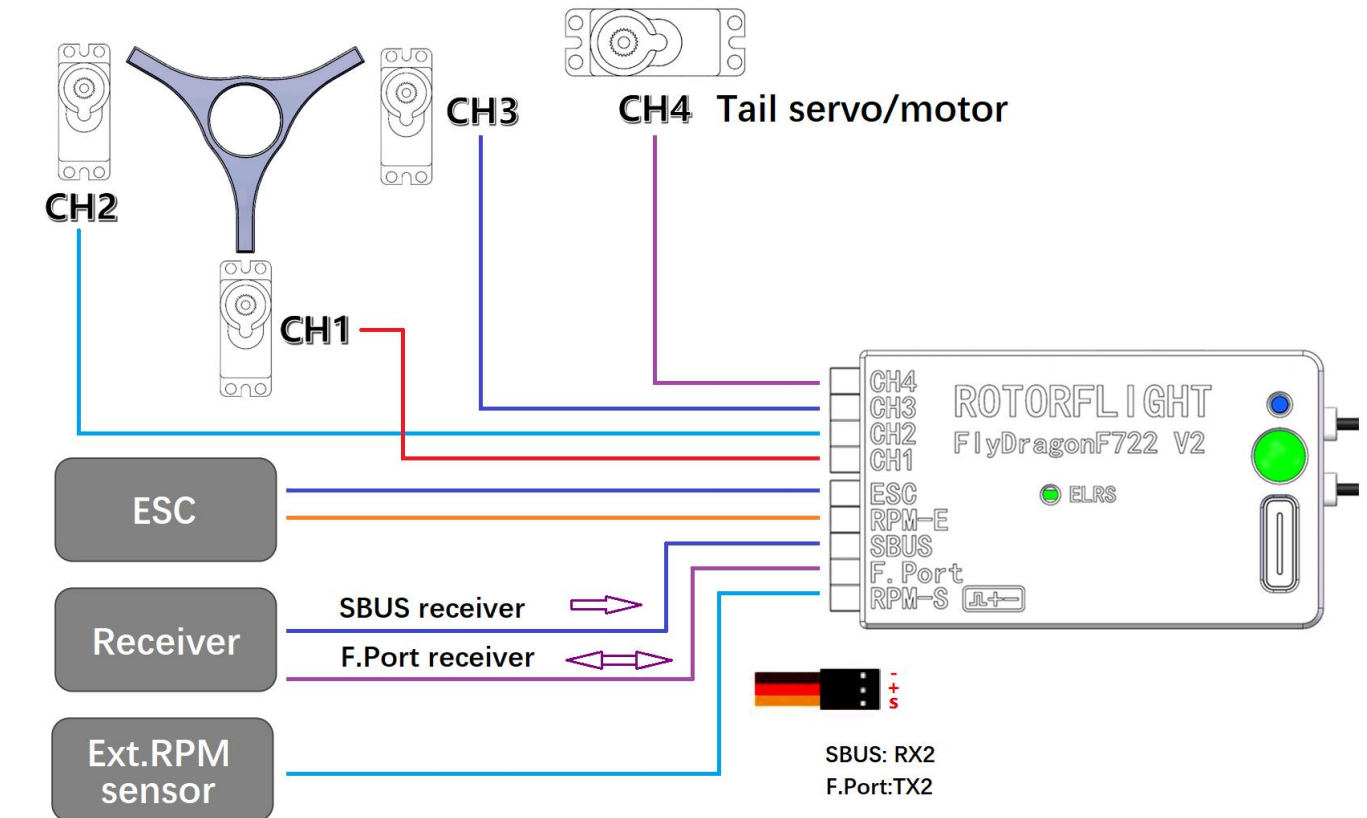

### Extension Port

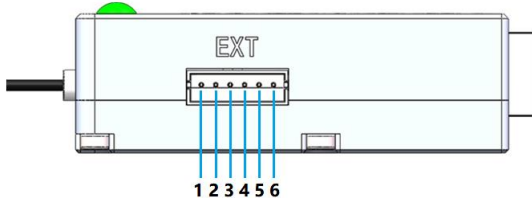

- 1: GND
  - 2: Battery Voltage Sensor. 0-52V (12S)
  - 3: Active Buzzer -
  - 4: UART TX3
  - 5: UART RX3
  - 6: 5V out (Active Buzzer +)
- Note: 5V out can only provide 1A current. Please do not connect high demand devices.

### GPS Port

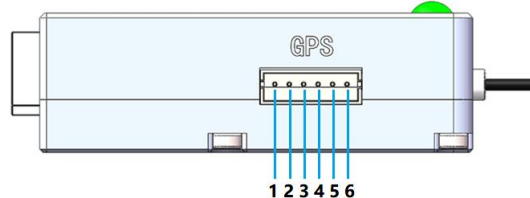

- 1: 5V out
- 2: UART RX5
- 3: UART TX5
- 4: I2C SCL1
- 5: I2C SDA1
- 6: GND

## Disclaimers:

RC helicopters are dangerous. If operated improperly, it may cause serious damage or even deaths. By using Flydragon F722 V2 FBL and Rotorflight firmware, you hereby agree that you are responsible for any damage it may cause. The authors/contributors of Rotorflight, the designer/distributor of Flydragon FBL shall NOT be held responsible for any direct, indirect, consequential, or special damages arising out of or in any way connected with your use of this product.

Rotorflight is Free Software. Meaning, it is available free of charge *without warranty*, the source code is available, and it is supported by the users themselves as a community. Rotorflight is under the GPLv3 license.